

Univers Alu Motor

Standard Einbauplan Liebungsmontage

Technische Spezifikationen:

Standard

Antrieb:	Motor 230V
Walze:	Ø 70mm
Antriebsseite:	links / rechts
Kabellänge:	50cm inkl. Stecker
Fallprofil:	Ø 30mm
Oberflächen:	Stahl verzinkt / Farblos eloxiert
Option:	RAL, NCS, IGP

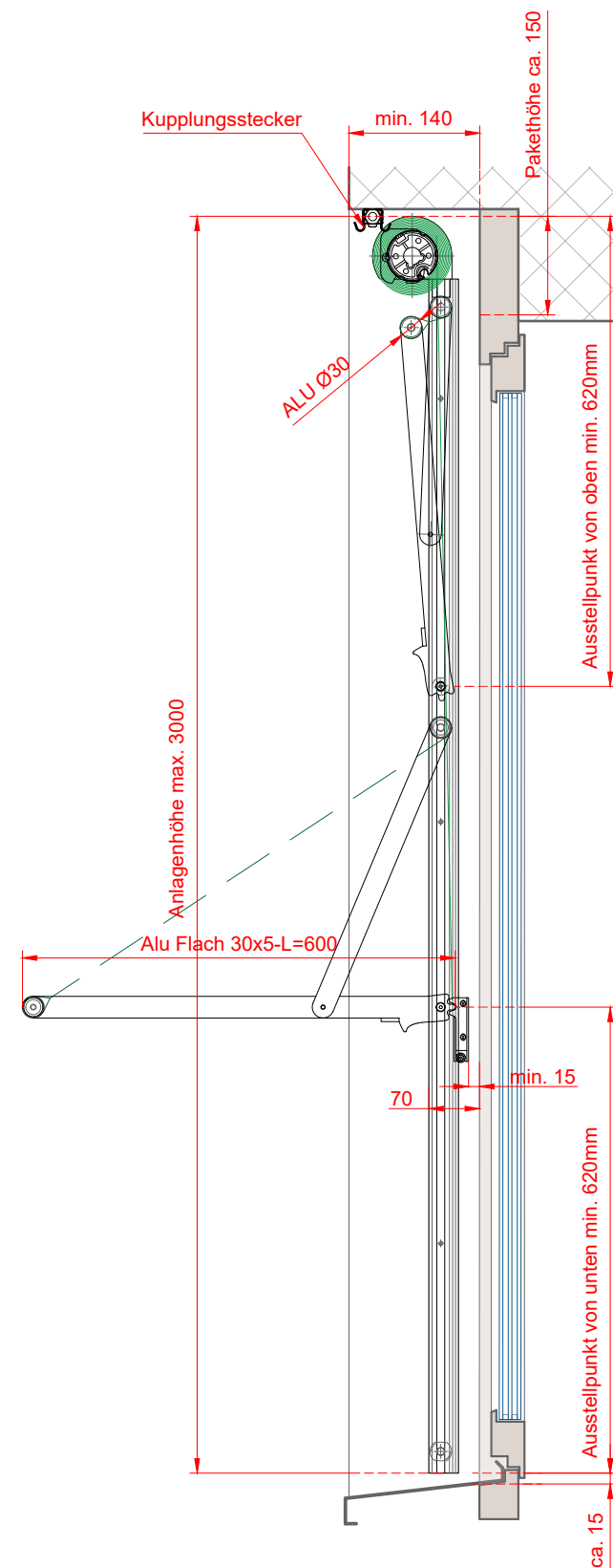
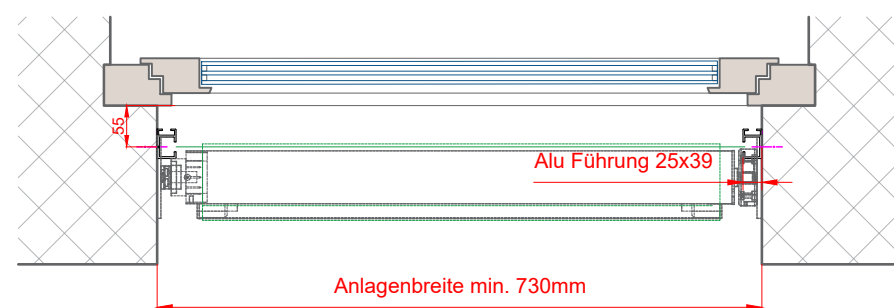
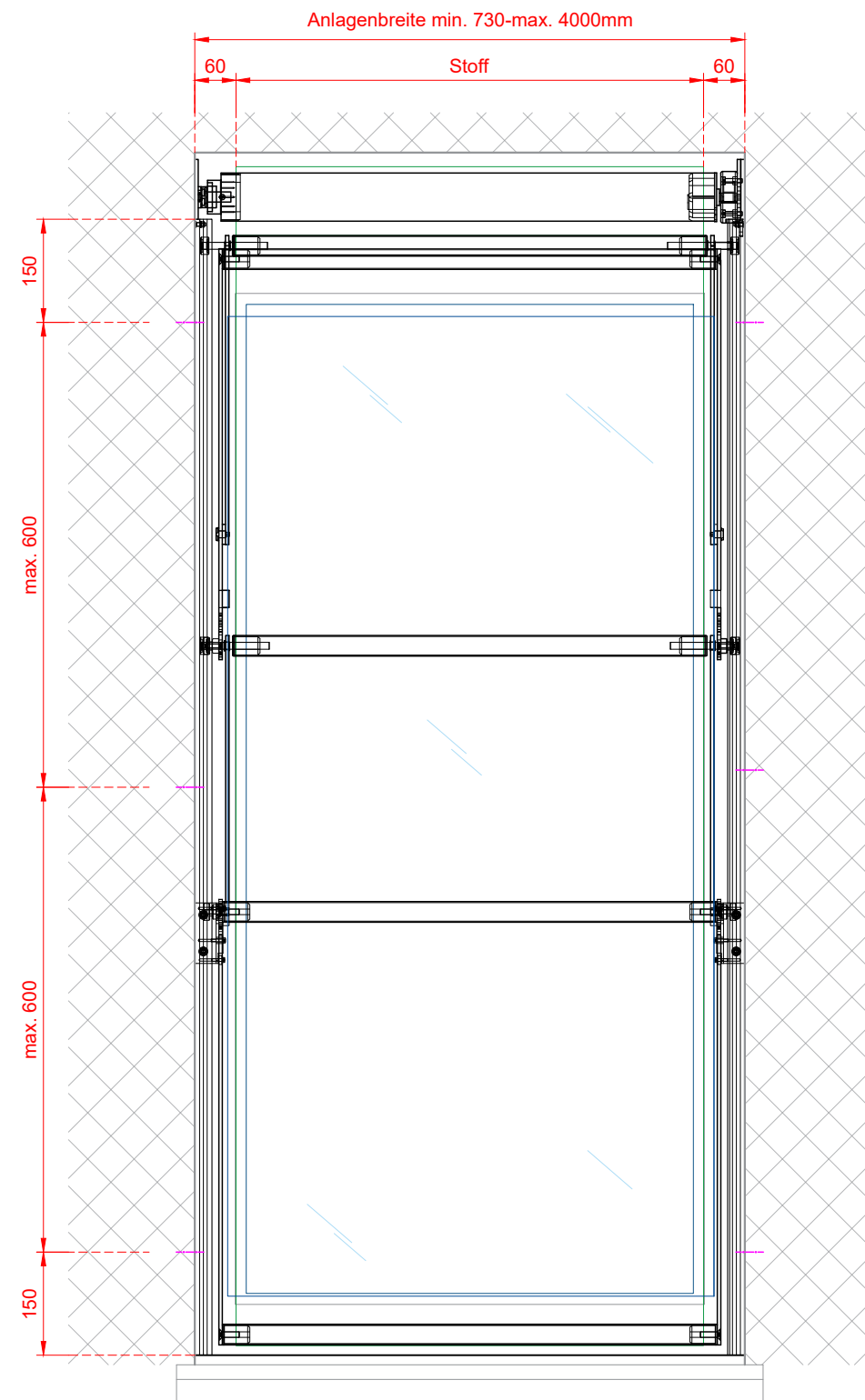

Datum:	17.06.2024	Erstellt:	mz
Msst:	1:10	Plan Nr:	662.1
Pfad:	Format:	A3
Rev.	Datum	Änderung	
.....	
.....	
.....	
.....	

STORAMA[®]
für mehr Wohlbefinden

Pfandersmatt
CH-3664 Burgstein Station
E-Mail: info@storama.ch
Tel. +41 33 359 80 80
Fax +41 33 359 80 70