

## Ansicht A

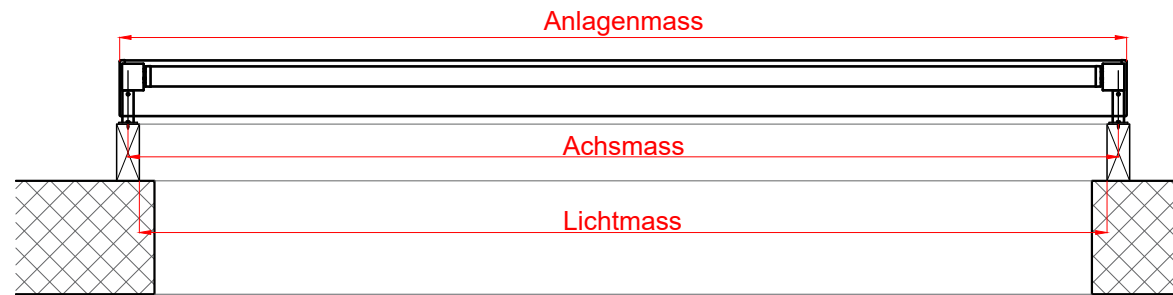

## Draufsicht

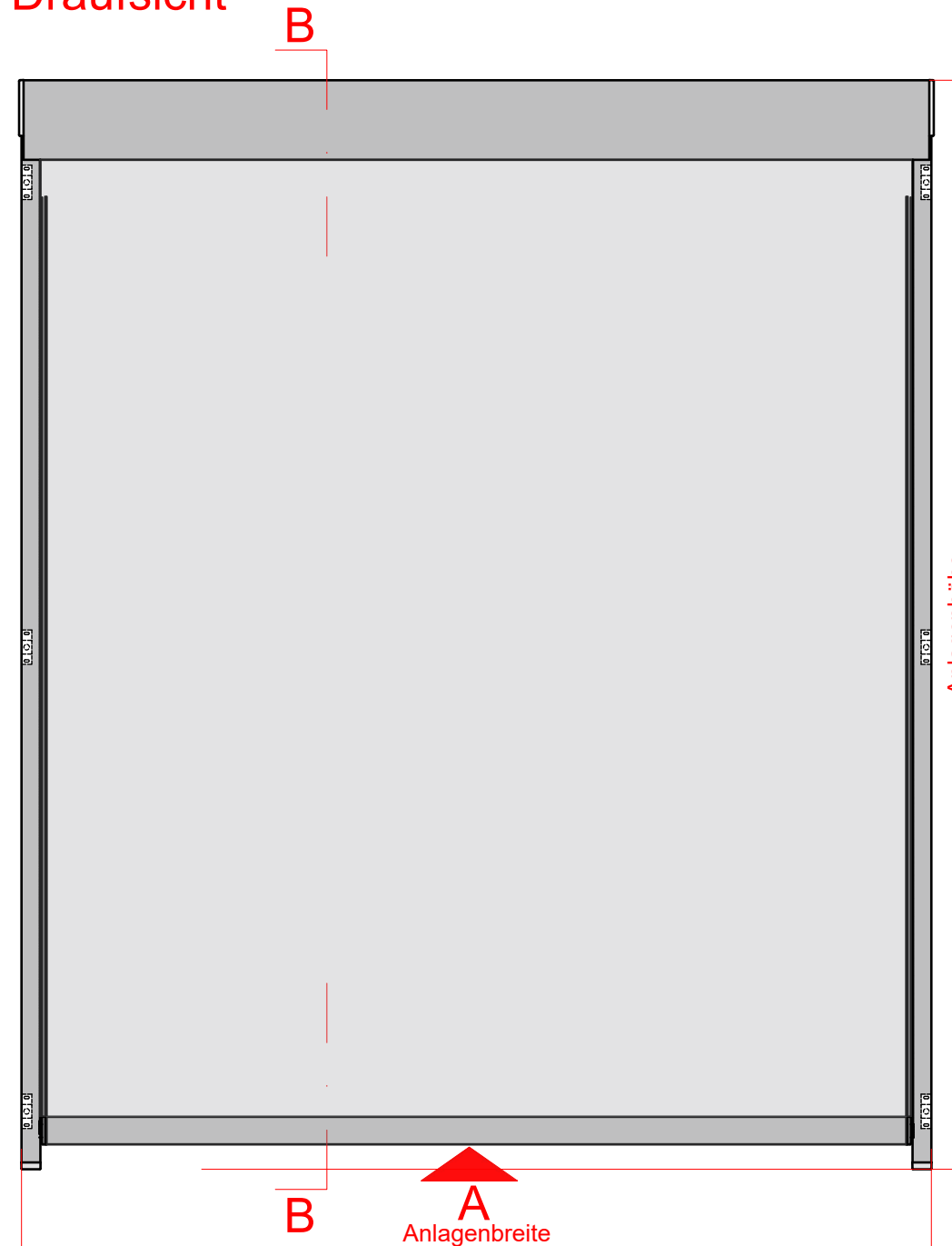

## Standard-Kabelabgang 1:5

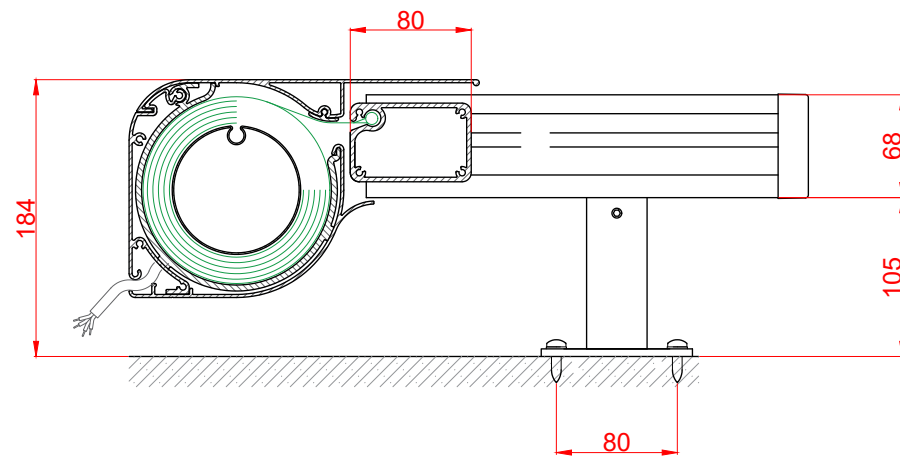

## Schnitt B-B

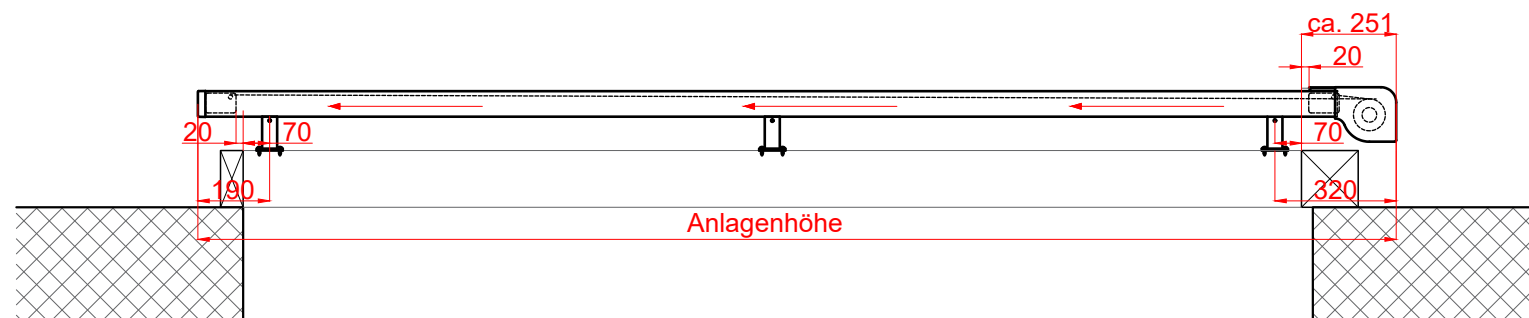

# W 350 Zip

## Wintergartenmarkise

Antrieb: Motor 230V

Gestellfarben:

RAL 9016  
RAL 9001  
RAL 9006  
RAL 9007  
RAL 7016  
RAL 8022

Gestellfarben Feinstruktur:

TIGER 29 / 90147  
ca. RAL 9007 FS

TIGER 29 / 60740  
Sepia Brown

TIGER 29 / 80077  
ca. DB 703 FS

TIGER 29 / 71289  
RAL 7016 FS

Sonderfarben möglich = Aufpreis

Datum:	22.01.2024	Erstellt:	mz
Msst:	1:20	Plan Nr.:	
Pfad:	.....	Format:	A3
Rev.	Datum	Änderung	
.....	.....	.....	
.....	.....	.....	
.....	.....	.....	
.....	.....	.....	

**STORAMA**<sup>®</sup>  
für mehr Wohlbefinden

Pfandersmatt  
CH-3664 Burgstein Station  
E-Mail: info@storama.ch  
Tel. +41 33 359 80 80  
Fax +41 33 359 80 70